

SWITCHES ON FINGERTIPS

Raunak Borwankar¹, Aditya Shenoy², Gaurav Pednekar³, Purva Sawant⁴

Department of Electronics Telecommunication, Don Bosco Institute of Technology,
Kurla (West), Mumbai 400 070, India

¹raun_borwankar@yahoo.co.in, ²aditya.shenoy1893@gmail.com, ³gpednekar@gmail.com,
⁴sawant.purva@gmail.com

Abstract

The document gives information on controlling all electrical devices viz. Tube lights, air-conditioners, computers, fans of every floor of the building from a single computer. To perform this task the main functional components are micro-controller and RS-485. This application can be accessed by the users anywhere anytime and from any device like desktop or laptop. This project is aimed at consumption of electricity by switching off the appliances. It is the future of corporate world due its various applications.

Keywords: Technology, Electricity, Micro-Controller, RS-485, Communication, Parameter

I. INTRODUCTION

This Technology make use of Micro-Controller, Rs-485 to control electrical devices. This Technology is very useful in corporate offices which helps in saving Electricity to a large extent. It can be also used in were quickly we have to cut the power supply of a particular place because of Fire or Gas Leaks. The technology currently used involves connection of every device individually to MCB's. In order to switch on and off, we need to adjust MCB. This project can control devices directly from PC.

II. MAIN BODY

The components used are MICRO-CONTROLLER (AVR ATMEGA 8) and Rs-485. First we make segments of electrical appliances that are to be operated by computer. For convenience we use separate relay boards for different appliances. Then connect those segments to respected relay board. The Host from where the operating takes place consist of a computer, micro-controller and Rs-485. The Micro-controller used is an AVR ATMEGA 8 so it is directly connected to pc through USB port.

AVR ATMEGA 8:



It is 8-bit micro-controller and consists of a variety of internal oscillators, timers, UARTs, SPIs, Pulse Width Modulation, pull-up resistors, ADCs, Analog Comparators and Watch-Dog Timers in it .

RS 485

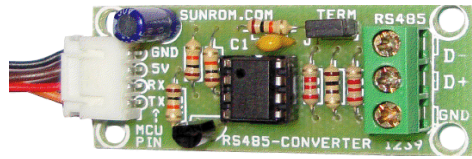

- Device needs to send & receive serial data to multiple locations at long distance.
- Provides RS485 interface to microcontrollers through their TX and RX pins to transmit/receive the serial data at long distance.
- Also provides reliable two wire RS485 link that can work up to 1.2 Km long twisted pair cable.
- When connected to any microcontroller serial UART pins the module can communicate in a bidirectional manner with any existing serial communication applications.
- .It can Transmit and Receive serial data at 9600 bps . Also it can be directly interface with microcontroller uart txd ,rxid pins. It works on merely 5 volts.
- The computer and micro-controller are connected by a RS-232 . RS- 485 communication and micro-controller are connected through pins. Both sides can be microcontroller. If you need PC at the other side, the PC can have RS232 to RS485 converter or USB to RS485 Converter.

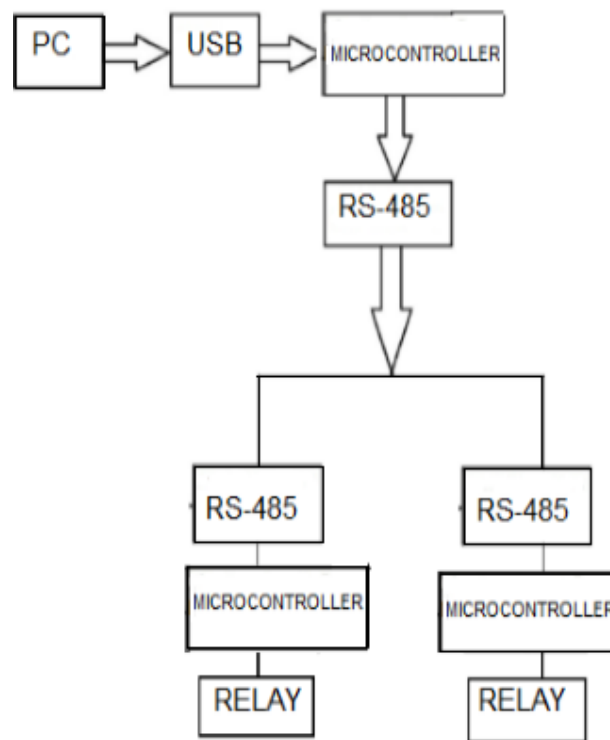

BLOCK DIAGRAM

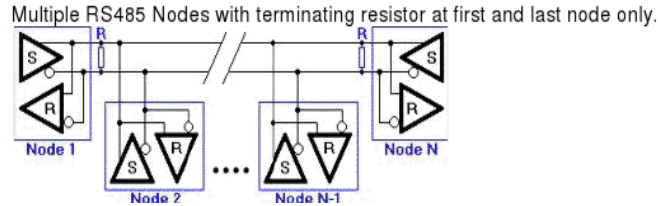
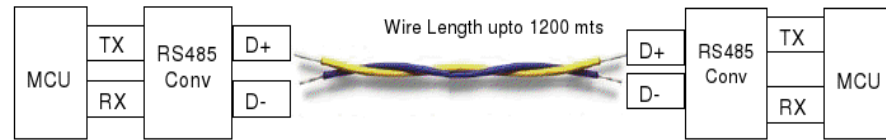

- The Rx-in of RS485 is connected to Txd of Micro-controller, while the Tx-out of RS485 is connected to Rxd of micro-controller .

The RS-485 is basically used to transfer data .The two RS-485 are connected through two pins.And then the RS-485 is connected to Micro-controller .The Micro-controller is then connected to relay board .

There is a Micro-controller and a RS-485 on every floor of a building .The micro-controller at host is provided with a parameter to select floor and then the control moves to the micro-controller on that very floor through a series of RS-485 .The selected micro-controller is then fed with parameters to select relay boards .If the appliances are to be closed all at once then we have to make use of SSR .These SSR are then connected to Relay Board .The Micro-controller is to be provided with a parameter in order to bring SSR in action .

The Relay board is provided with external AC supply through SSR .The Micro-controller and RS-485 is given 5 volts externally.

III. CONCLUSIONS

The paper introduces about pc controlled electronic devices which can have a wide scope in future as it saves energy to a great extent. It can also be used in commercial buildings to a great effect with ease. It ensures safety and security with its various applications.

IV. CURRENT WORK PROGRESS

The technology currently uses RS-485 for communication purpose.Using sensors gas leak or fire break is detected.At a time any number of appliances can be controlled. This project can be extended to keep a check on the number of people in the room and accordingly controlling appliances. The future scope in developing this project is powerline communication.

REFERENCES

1. <http://www.engadget.com/2012/08/19/bluetooth-bulb-lets-you-switch-on-time-dim-and-color/>
2. <http://www.codeproject.com/Articles/7239/Control-Electrical-Appliances-using-PC>
3. <http://soe.rutgers.edu/sites/default/files/gset/CCL.pdf>